

**Optional Stanchion Mounted Rail**

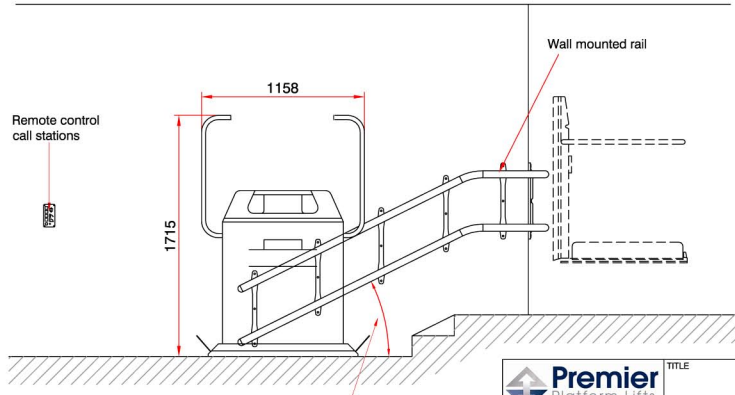
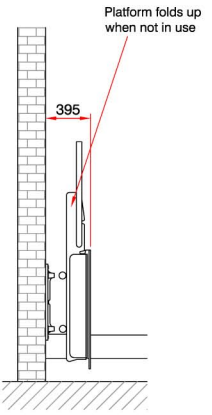

**Stairiser Platform Specification**

- Load: 230kg / 1 wheelchair
- Drive: Rack and Pinion
- Speed: 0.01m / sec
- Travel: subject to survey
- Stops: 2
- Motor: 1.1kw
- Power: 240v 1ph 50Hz 10A
- Colour: RAL 7035 as standard (alternative RAL colours available)

**Premier Platform Lifts**  
 www.ppl.ie  
 Premier Platform Lifts  
 County, Mountshannon, Co. Clare, Ireland  
 Tel: +353 (0)61 922 903  
 Fax: +353 (0)61 922 904  
 Email: info@ppl.ie  
 Web: www.ppl.ie

TITLE		<b>C6 - Curved Stairiser</b>	
DWG NO.	<b>230 - C6 - PLAN</b>		REV
SCALE	NTS	DATE	28/09/06
DRAWN	RH		A

Note - Platform carriage available as a left hand or right hand unit

Stair Angle = 20° to 40°