

NOTE THIS DRAWING IS FOR GUIDANCE ONLY AND MUST NOT BE USED AS A PROPER WORKING DRAWING. FOR ENQUIRIES ABOUT THE LIFT PLEASE CONTACT 061 922 903

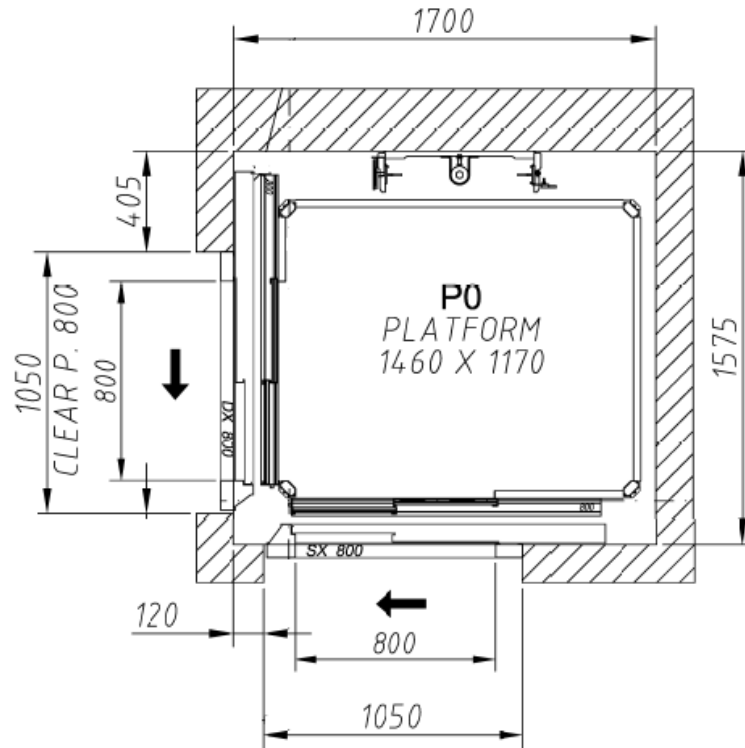

LIFT STD SPECIFICATION

Load capacity	300kg
Drive system	Hydraulic 2:1 Roped
Speed	0.15 m/s
Maximum number of stops	5
Maximum Travel	9.25m
Pit Depth	140mm
Minimum Headroom	2600mm
Power	230V-mono AC – 50Hz
Motor	1.8 kW
Cabin COP	Full height Vertical
Car Controls	One touch
Landing Controls	One Touch
Cabin Ceiling	LED bar
Cabin Finish	Skin-plate
Door Type	telescopic 2 speed
Door Finish	Skin-plate
Communication	Telephone
Structure	Self-Supporting Structure
Structure Finish	Steel in RAL 7040, Fully glazed on 3 sides.

Options

- LCD Display
- Voice Announcement
- Cabin Mirror
- Handrail
- Auto-dialer
- Numerous Cabin Finishes
- Various door options
- 60min Fire rated doors
- Alternative RAL Finishes to Structure & Doors

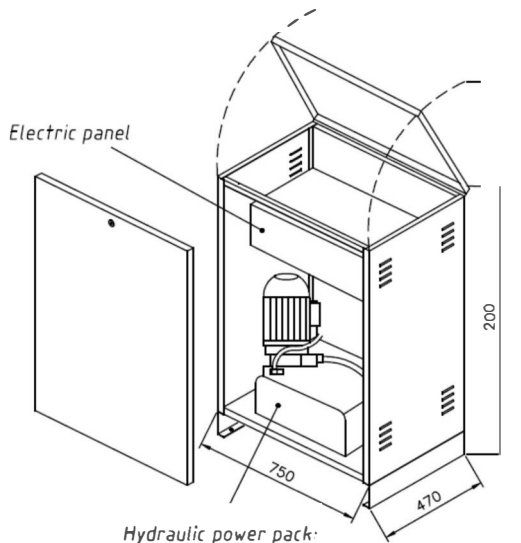

Hydraulic Cabinet, to be sited within 12 metres of the lift shaft. A 100mm conduit run for cables & hoses needs to be provided.

 PREMIER LIFTS www.lifts.ie	VPL500 – Self Supporting Structure – 1460mm x 1170mm		
	Through Entry/Exit – telescopic doors		
Premier Lifts, Glean Glas House, Tuamgraney, Co. Clare, Ireland. Tel: 061 922 903 Email: info@lifts.ie Fax: 061 922 904 Web: www.lifts.ie	DWG NO - 0023	REV - A	
	SCALE	DATE	DRAWN
	N/A	14/11/2017	APG